

**NOTES:**

1. REARRANGEMENT OF AIRCRAFT LAYOUT OF PASSENGER ACCOMMODATIONS IS TO BE PERFORMED IAW THIS DRAWING AND INSTRUCTIONS SHOWN ON AIRE SERVICE BULLETIN NO. A320C289-SB001.
2. AISLE WIDTHS MUST MEET REQUIREMENTS SET FORTH IN JAR §25.815.
3. EMERGENCY EXITS MUST BE ACCESSIBLE PER JAR §25.813.
4. EMERGENCY EXITS MUST BE MARKED IN ACCORDANCE WITH JAR §25.811.
5. ALL LIFE VESTS MUST CONFORM TO J/E/TSO C-13.
6. CREW OXYGEN MASKS MUST MEET ALL REQUIREMENTS IN JAR §25.1439.
7. STORAGE PROVISIONS FOR ALL EMERGENCY EQUIPMENT MUST BE MARKED TO IDENTIFY THEIR CONTENTS IAW JAR §25.1561.
8. "FASTEN SEAT BELT" AND "NO SMOKING" SIGNS MUST BE VISIBLE TO EACH PERSON SEATED IN THE PASSENGER CABIN.
9. ALL SEAT BACKS AND BULKHEADS MUST HAVE "FASTEN SEAT BELT WHILE SEATED" PLACARD.
10. SEAT REFERENCE LINE IS TAKEN FROM POINT OF ATTACHMENT TO AIRCRAFT SEAT TRACKS.
11. ALL SEATS MUST CONFORM TO RESPECTIVE TSO/ETSO.
12. TIGHTEN THE REAR TRACK FITTING FASTENER AS PER SEATS' RESPECTIVE CMM INDICATION.
13. INSTALLATION AND SEATS TOLERANCE AS PER CMM.

**POST-INSTALLATION NOTES:**

- A. ENSURE EACH OXYGEN MASK DROPS WITHIN THE REQUIRED ZONE ABOVE PASSENGER SEAT.
- B. ENSURE NO SMOKING/FASTEN SEAT BELT SIGN IS VISIBLE TO EACH PASSENGER WHILE SEATED.
- C. ENSURE EMERGENCY ESCAPE PATH MARKING IS DIRECTLY VISIBLE ALONG THE WHOLE PASSENGER CABIN AND ALSO NO OBJECT OR CARPET COVERS IT AT ANY POINT OF EMERGENCY EXIT AISLES.
- D. REQUIRED AISLE WIDTH DIMENSIONS IN COMPLIANCE WITH JAR 25.
- E. SEATS AT FIRST ROWS ARE TO HAVE MINIMUM HEADSTRIKE CLEARANCE OF 35" FROM SEAT REFERENCE POINT.
- F. ENSURE THAT EACH SEAT HAS LIFE VEST INSTALLED.
- G. MAKE SURE THAT LIFE VEST LOCATION IS PROPERLY INDICATED IN A VISIBLE PLACE.

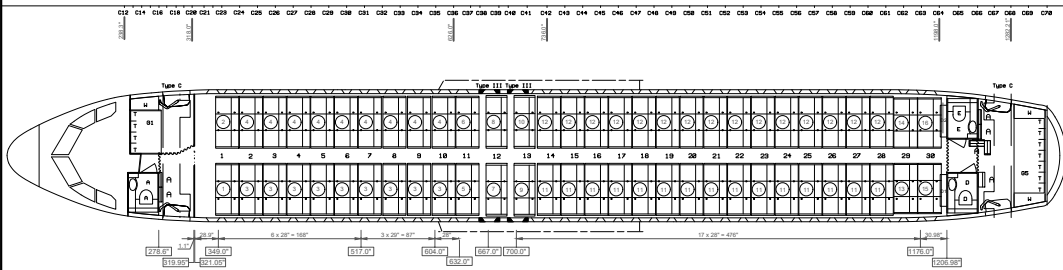

**FIGURE 1 - B1. PASSENGER SEATS CONFIGURATION AFTER IMPLEMENTATION OF DESIGN CHANGE**

**ABBREVIATION LIST**

- TPL - TRIPLE
- IAT - IN ARM TABLE
- STD - STANDARD
- DP - DISABLE PEOPLE
- NR - NO RECLINE
- SPCL LATCH - SPECIAL LATCH
- E.E - EMERGENCY EXIT
- NOA - NO OUTBOARD ARMREST
- B.O - BREAK OVER
- RR TABLES - REAR TABLES

**REVISIONS**

ISSUE	DATE	REASON OF CHANGE	PREPARED BY	VERIFIED BY
1	23/04/2024	Initial Issue	DESIGN OFFICE	CVE

**PART LIST**

ITEM	PART NUMBER	DESCRIPTION	QTY
1	3510A377-31-213	SEAT ASSY, LH, TPL, IAT	1
2	3510A377-32-213	SEAT ASSY, RH, TPL, IAT	1
3	3510A377-31-013	SEAT ASSY, LH, TPL, STD	9
4	3510A377-32-013	SEAT ASSY, RH, TPL, STD	9
5	3510A377-31-043	SEAT ASSY, LH, TPL, NR, NO COAT HOOK, SPECIAL LATCH	1
6	3510A377-32-043	SEAT ASSY, RH, TPL, NR, NO COAT HOOK, SPECIAL LATCH	1
7	3510A377-31-472	SEAT ASSY, LH, TPL, IAT, NR, SPEC UPRIGHT, SPECIAL LATCH, NO COAT HOOK, NO OUTBOARD ARMREST, SPECIAL SEAT CUSHION OUTBOARD	1
8	3510A377-32-472	SEAT ASSY, RH, TPL, IAT, NR, SPEC UPRIGHT, SPECIAL LATCH, NO COAT HOOK, NO OUTBOARD ARMREST, SPECIAL SEAT CUSHION OUTBOARD	1
9	3510A377-31-482	SEAT ASSY, LH, TPL, IAT, NO OUTBOARD ARMREST, SPECIAL SEAT CUSHION OUTBOARD	1
10	3510A377-32-482	SEAT ASSY, RH, TPL, IAT, NO OUTBOARD ARMREST, SPECIAL SEAT CUSHION OUTBOARD	1
11	3510A377-31-023	SEAT ASSY, LH, TPL, LIM RECLINE 2"	15
12	3510A377-32-023	SEAT ASSY, RH, TPL, LIM RECLINE 2"	15
13	3510A377-31-033	SEAT ASSY, LH, TPL, LIM RECLINE 2", STRETCHER PROVISIONS	1
14	3510A377-32-033	SEAT ASSY, RH, TPL, LIM RECLINE 2", STRETCHER PROVISIONS	1
15	3510A377-31-112	SEAT ASSY, LH, TPL, LIM RECLINE 2"	1
16	3510A377-32-112	SEAT ASSY, RH, TPL, LIM RECLINE 2"	1

**DRAWING INFORMATION:**  
This drawing is property of AIRE SL. It is issued on the condition that it is not copied, reproduced or disclosed to a third party either whole or in part without the consent in writing of AIRE SL



**TITLE:**  
LAYOUT OF PASSENGER ACCOMODATION  
MSN 2828

**PREPARED BY:**  
DESIGN OFFICE

**REFERENCE:**  
DWG-A320C289-001-LOPA

**SIGNATURE ON SHEET 1**

**AIRCRAFT TYPE:**  
AIRBUS A320-200

**DIM:** in  
**SCALE:** N/A  
**SHEET:** 1/4  
**ISSUE:** 1

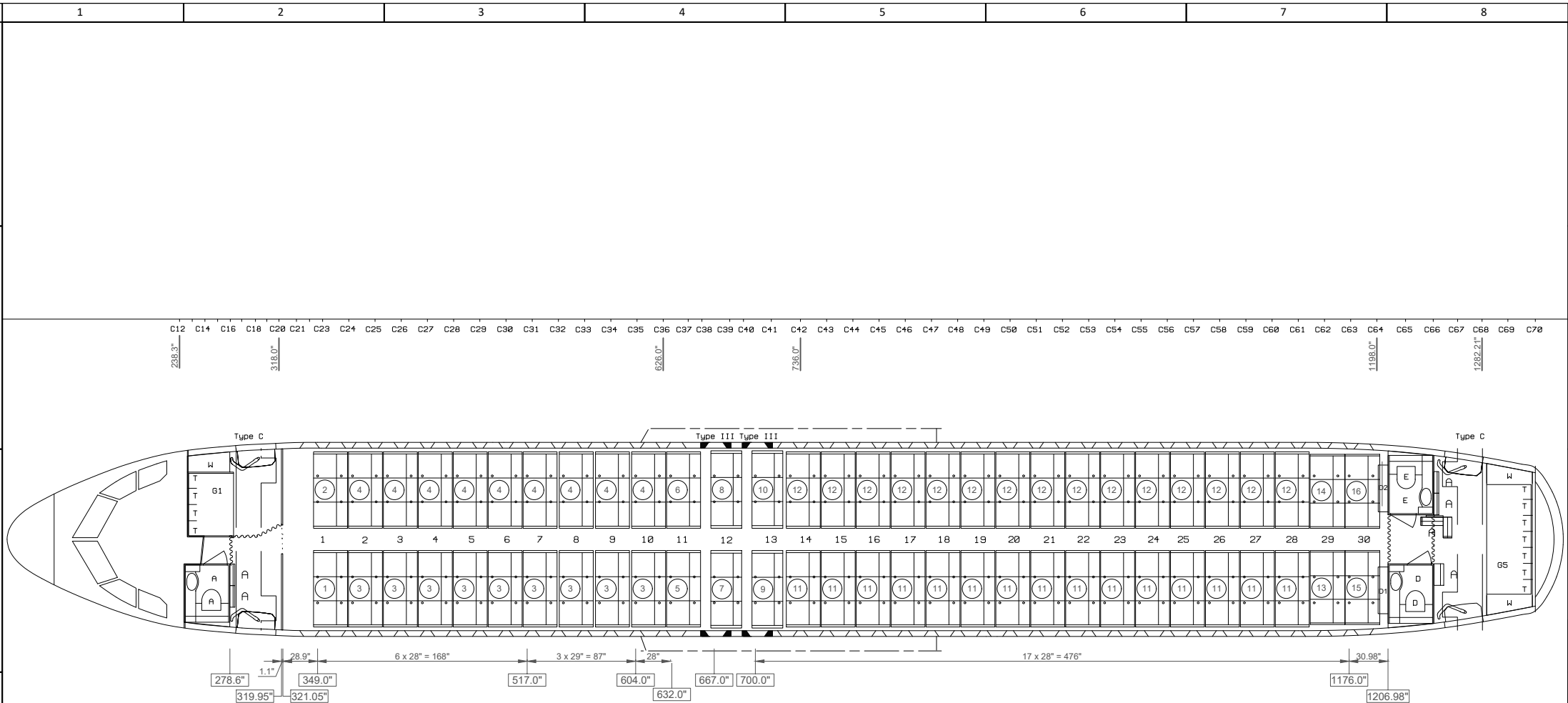

FIGURE 2-E1. LAYOUT OF PASSENGER ACCOMMODATIONS

(REFER TO SHEET 1 FOR FURTHER INFORMATION)

<p><b>DRAWING INFORMATION:</b> This drawing is property of AIRE SL. It is issued on the condition that it is not copied, reproduced or disclosed to a third party either whole or in part without the consent in writing of AIRE SL</p>			<p><b>TITLE:</b> LAYOUT OF PASSENGER ACCOMODATION MSN 2828</p>		
	<p><b>PREPARED BY:</b> DESIGN OFFICE</p>		<p><b>REFERENCE:</b> DWG-A320C289-001-LOPA</p>		
	<p><b>SIGNATURE</b> ON SHEET 1</p>		<p><b>AIRCRAFT TYPE:</b> AIRBUS A320-200</p>		
		<p><b>DIM:</b> in</p>		<p><b>SCALE:</b> N/A</p>	
				<p><b>SHEET:</b> 2/4</p>	
				<p><b>ISSUE:</b> 1</p>	

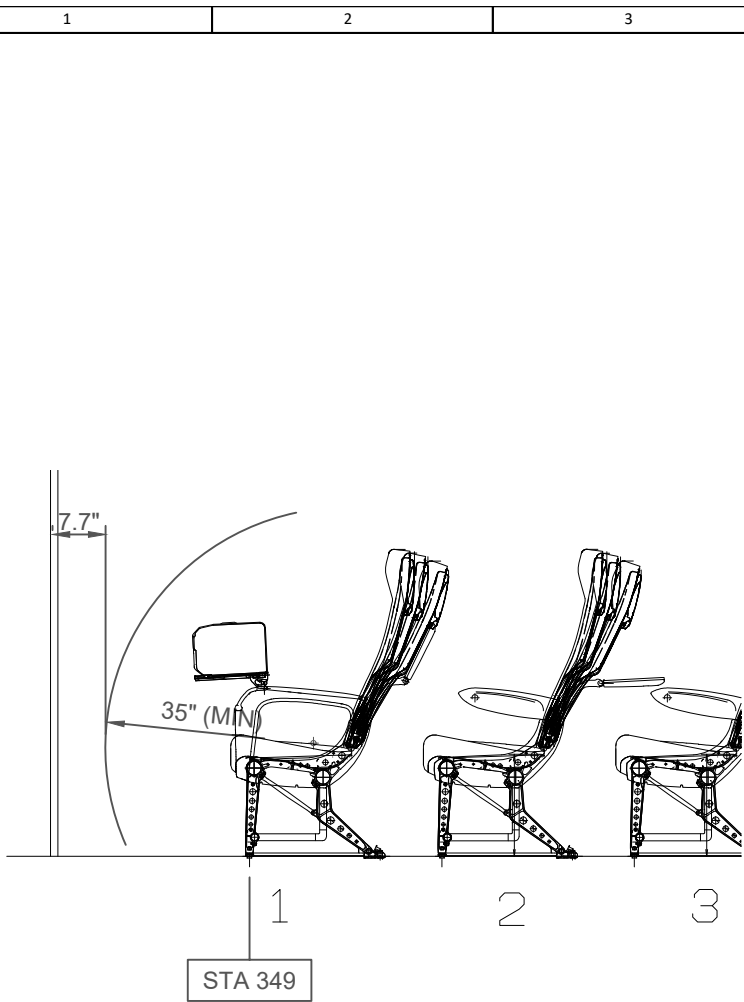

FIGURE 3-D1. LATERAL VIEW FIRST SEAT ROW TO BULKHEAD

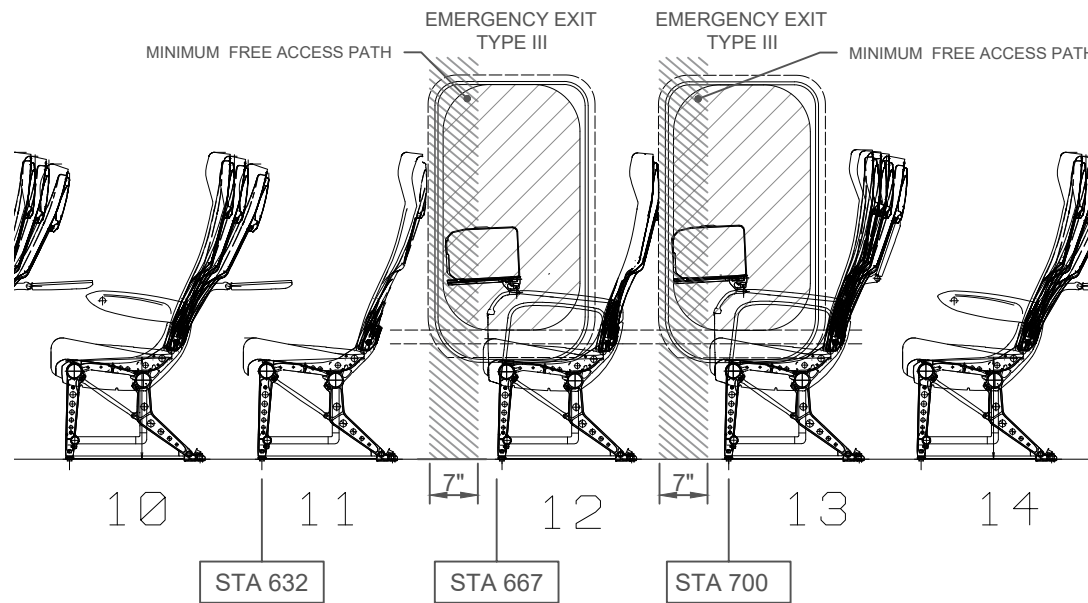

FIGURE 3-D4. LATERAL VIEW - EMERGENCY EXIT SEATS

(REFER TO SHEET 1 FOR FURTHER INFORMATION)

<p><b>DRAWING INFORMATION:</b> This drawing is property of AIRE SL. It is issued on the condition that it is not copied, reproduced or disclosed to a third party either whole or in part without the consent in writing of AIRE SL</p>	<p><b>AIRE</b> TITLE: LAYOUT OF PASSENGER ACCOMODATION MSN 2828</p>		
	<p>PREPARED BY: DESIGN OFFICE</p>	<p>REFERENCE: DWG-A320C289-001-LOPA</p>	<p>DIM: in SCALE: N/A</p>
	<p>SIGNATURE ON SHEET 1</p>	<p>AIRCRAFT TYPE: AIRBUS A320-200</p>	<p>SHEET: 3/4 ISSUE: 1</p>

FRAME 21 (FIRST ROW)

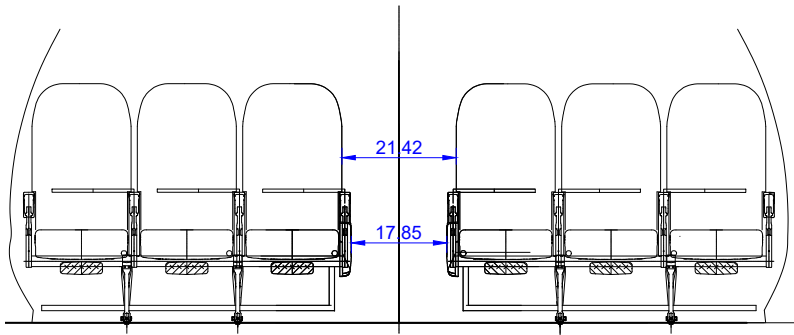

FIGURE 4-E1. FRONT VIEW FIRST ROW

FRAME 38-41 (OVERWING EXIT)

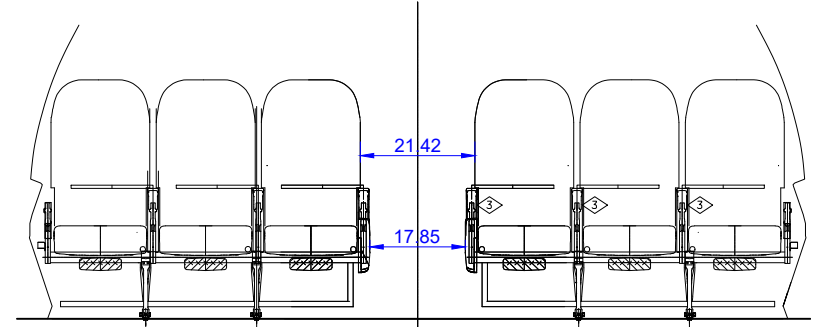

FIGURE 4-E5. FRONT VIEW EMERGENCY EXIT SEAT

ROW 26 (STD SEAT)

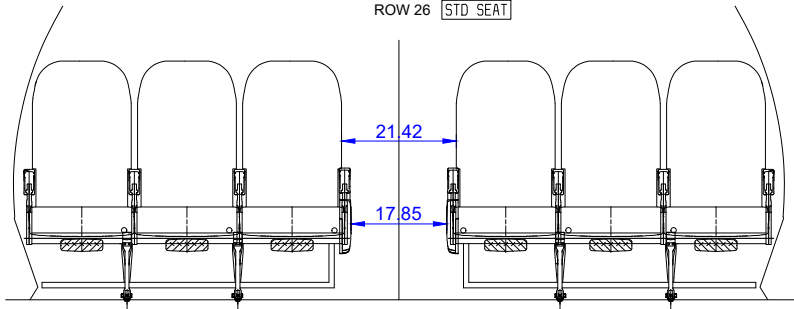

FIGURE 4-C1. FRONT VIEW STANDARD SEAT

ROW 30 (LAST ROW) NARROW SEAT

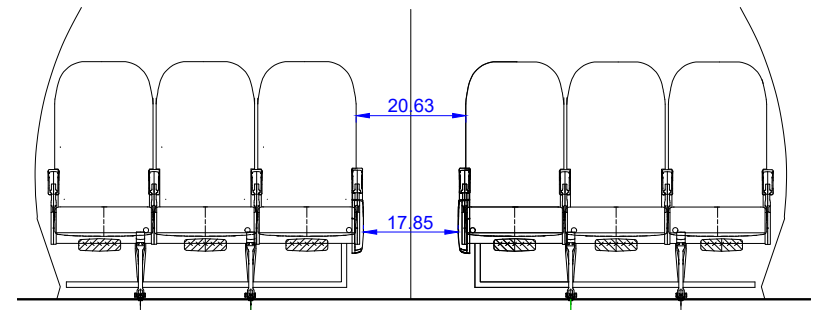

FIGURE 4-C5. FRONT VIEW LAST ROW SEATS

(REFER TO SHEET 1 FOR FURTHER INFORMATION)

**DRAWING INFORMATION:**  
This drawing is property of AIRE SL. It is issued on the condition that it is not copied, reproduced or disclosed to a third party either whole or in part without the consent in writing of AIRE SL



**TITLE:**  
LAYOUT OF PASSENGER ACCOMODATION  
MSN 2828

**PREPARED BY:**  
DESIGN OFFICE

**REFERENCE:**  
DWG-A320C289-001-LOPA

**DIM:** in  
**SCALE:** N/A

**SIGNATURE**  
ON SHEET 1

**AIRCRAFT TYPE:**  
AIRBUS A320-200

**SHEET:** 4/4  
**ISSUE:** 1