

**NOTES:**

1. REARRANGEMENT OF AIRCRAFT LAYOUT OF PASSENGER ACCOMMODATIONS IS TO BE PERFORMED IAW THIS DRAWING AND INSTRUCTIONS SHOWN ON AIRE SERVICE BULLETIN NO. A320C110-SB001
2. AISLE WIDTHS MUST MEET REQUIREMENTS SET FORTH IN EASA §25.815
3. EMERGENCY EXITS MUST BE ACCESSIBLE PER EASA §25.813
4. EMERGENCY EXITS MUST BE MARKED IN ACCORDANCE WITH EASA §25.811
5. ALL LIFE VESTS MUST CONFORM TO J/E/TSO C-13
6. CREW OXYGEN MASKS MUST MEET ALL REQUIREMENTS IN EASA CS 25.1439
7. STORAGE PROVISIONS FOR ALL EMERGENCY EQUIPMENT MUST BE MARKED TO IDENTIFY THEIR CONTENTS IAW EASA §25.1561
8. "FASTEN SEAT BELT" AND "NO SMOKING" SIGNS MUST BE VISIBLE TO EACH PERSON SEATED IN THE PASSENGER CABIN
9. ALL SEAT BACKS AND BULKHEADS MUST HAVE "FASTEN SEAT BELT WHILE SEATED" PLACARD
10. SEAT REFERENCE LINE IS TAKEN FROM POINT OF ATTACHMENT TO AIRCRAFT SEAT TRACKS
11. ALL SEATS MUST CONFORM TO RESPECTIVE TSO/ETSO
12. TIGHTEN THE REAR TRACK FITTING FASTENER AS PER SEATS' RESPECTIVE CMM INDICATION.
13. INSTALLATION AND SEATS TOLERANCE AS PER CMM
14. INSTALL SEAT ROW PLACARDS IAW AMM.

**POST-INSTALLATION NOTES:**

- A. ENSURE EACH OXYGEN MASK DROPS WITHIN THE REQUIRED ZONE ABOVE PASSENGER SEAT
- B. ENSURE NO SMOKING/FASTEN SEAT BELT SIGN IS VISIBLE TO EACH PASSENGER WHILE SEATED
- C. ENSURE EMERGENCY ESCAPE PATH MARKING IS DIRECTLY VISIBLE ALONG THE WHOLE PASSENGER CABIN AND ALSO NO OBJECT OR CARPET COVERS IT AT ANY POINT OF EMERGENCY EXIT AISLES
- D. REQUIRED AISLE WIDTH DIMENSIONS IN COMPLIANCE WITH EASA CS25
- E. SEATS AT FIRST ROWS ARE TO HAVE MINIMUM HEADSTRIKE CLEARANCE OF 35" FROM SEAT REFERENCE POINT
- F. ENSURE THAT EACH SEAT HAS LIFE VEST INSTALLED.
- G. MAKE SURE THAT LIFE VEST LOCATION IS PROPERLY INDICATED IN A VISIBLE PLACE

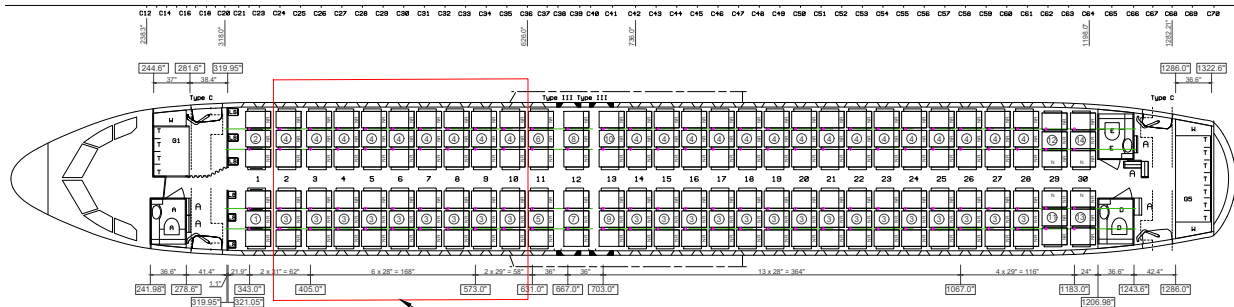

MODIFIED AREA

**REVISIONS**

ISSUE	DATE	REASON OF CHANGE	PREPARED BY	VERIFIED BY
1	21/03/2023	Initial Issue	DESIGN OFFICE	CVE

**SEATS - PART LIST**

ITEM	PART NUMBER	DESCRIPTION	QTY
1	C5-03-103-1WZ	SEAT, TRIPLE, IN-ARM TABLE, LH, NO RECLINE	1
2	C5-03-104-1WZ	SEAT, TRIPLE, IN-ARM TABLE, RH, NO RECLINE	1
3	C5-03-131-1WZ	SEAT, TRIPLE, LH, NO RECLINE, DISABLE PEOPLE ARMREST	24
4	C5-03-132-1WZ	SEAT, TRIPLE, RH, NO RECLINE, DISABLE PEOPLE ARMREST	24
5	C5-03-133-1WZ	SEAT, TRIPLE, LH, NO RECLINE, DISABLE PEOPLE ARMREST, SL	1
6	C5-03-134-1WZ	SEAT, TRIPLE, RH, NO RECLINE, DISABLE PEOPLE ARMREST, SL	1
7	C5-03-135-1WZ	SEAT, TRIPLE, LH, NO RECLINE, SL, NOT OUTBOARD ARM	1
8	C5-03-136-1WZ	SEAT, TRIPLE, RH, NO RECLINE, SL, NOT OUTBOARD ARM	1
9	C5-03-137-1WZ	SEAT, TRIPLE, LH, NO RECLINE, NOT OUTBOARD ARM	1
10	C5-03-138-1WZ	SEAT, TRIPLE, RH, NO RECLINE, NOT OUTBOARD ARM	1
11	C5-03-185-1WZ	SEAT, TRIPLE, NARROW, LH, NO RECLINE, DISABLE PEOPLE ARMREST	1
12	C5-03-186-1WZ	SEAT, TRIPLE, NARROW, RH, NO RECLINE, DISABLE PEOPLE ARMREST	1
13	C5-03-187-1WZ	SEAT, TRIPLE, NARROW, LH, NO RECLINE, DISABLE PEOPLE ARMREST, NO REAR TABLE	1
14	C5-03-188-1WZ	SEAT, TRIPLE, NARROW, RH, NO RECLINE, DISABLE PEOPLE ARMREST, NO REAR TABLE	1

**DRAWING INFORMATION:**

This drawing is property of AIRE SL. It is issued on the condition that it is not copied, reproduced or disclosed to a third party either whole or in part without the consent in writing of AIRE SL



**TITLE:**  
LAYOUT OF PASSENGER ACCOMMODATIONS IN AIRBUS A320 MSN 3947

**PREPARED BY:**  
DESIGN OFFICE

**REFERENCE:**  
DWG-A320C110-3947-LOPA

SIGNATURE ON SHEET 1

**AIRCRAFT TYPE:**  
AIRBUS A320-232

**DIM:** in  
**SCALE:** N/A  
**SHEET:** 1/3  
**ISSUE:** 1

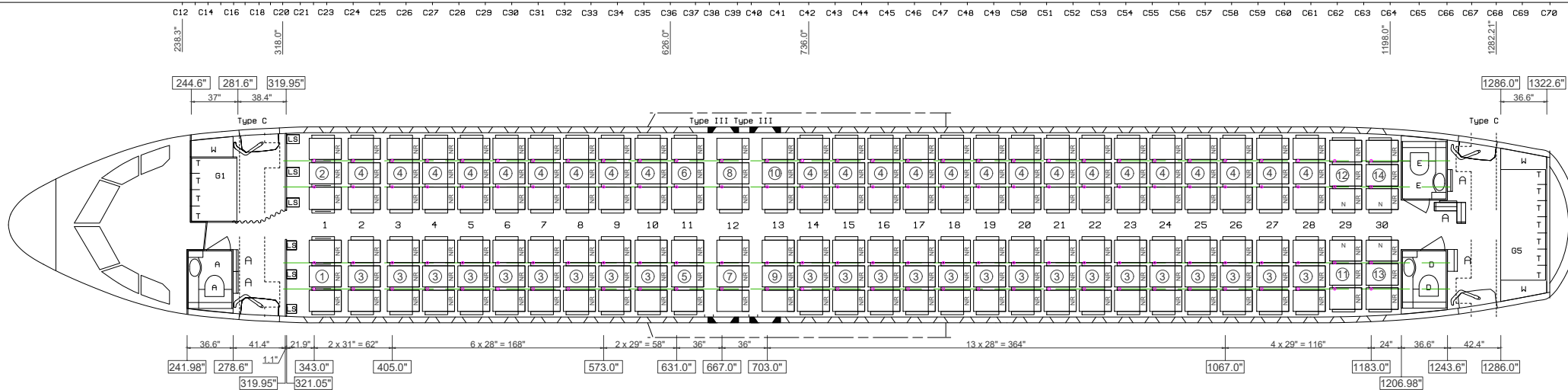

FIGURE 2-E1. LAYOUT OF PASSENGER ACCOMMODATIONS

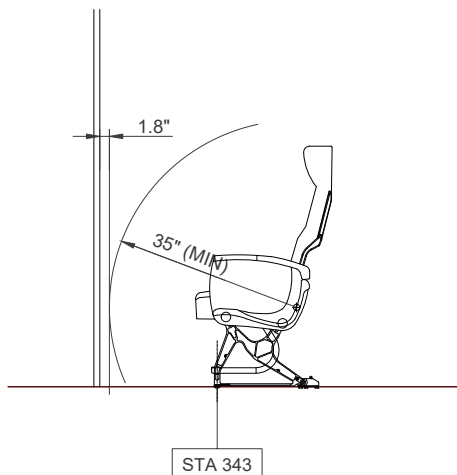

FIGURE 2 - C1. FIRST ROW - MINIMUM DISTANCE TO BULKHEAD - HIC ARCUS

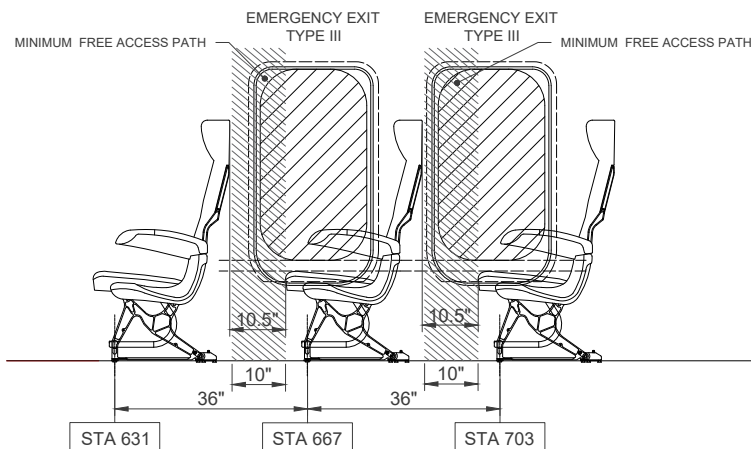

FIGURE 2 - C3. PASSENGER SEATS LOCATION IN OVERWING AREA - EMERGENCY EXITS FREE ACCESS PATH

N	NARROW SEAT
NR	NO RECLINE
LS	LITERATURE POCKET
—	IN ARMREST TABLE

(REFER TO SHEET 1 FOR FURTHER INFORMATION)

**DRAWING INFORMATION:**  
This drawing is property of AIRE SL. It is issued on the condition that it is not copied, reproduced or disclosed to a third party either whole or in part without the consent in writing of AIRE SL

<b>AIRE</b>	<b>TITLE:</b> LAYOUT OF PASSENGER ACCOMMODATIONS IN AIRBUS A320 MSN 3947	
	<b>PREPARED BY:</b> DESIGN OFFICE	<b>REFERENCE:</b> DWG-A320C110-3947-LOPA
<b>SIGNATURE</b> ON SHEET 1	<b>AIRCRAFT TYPE:</b> AIRBUS A320-232	<b>DIM:</b> in <b>SCALE:</b> N/A <b>SHEET:</b> 2/3 <b>ISSUE:</b> 1

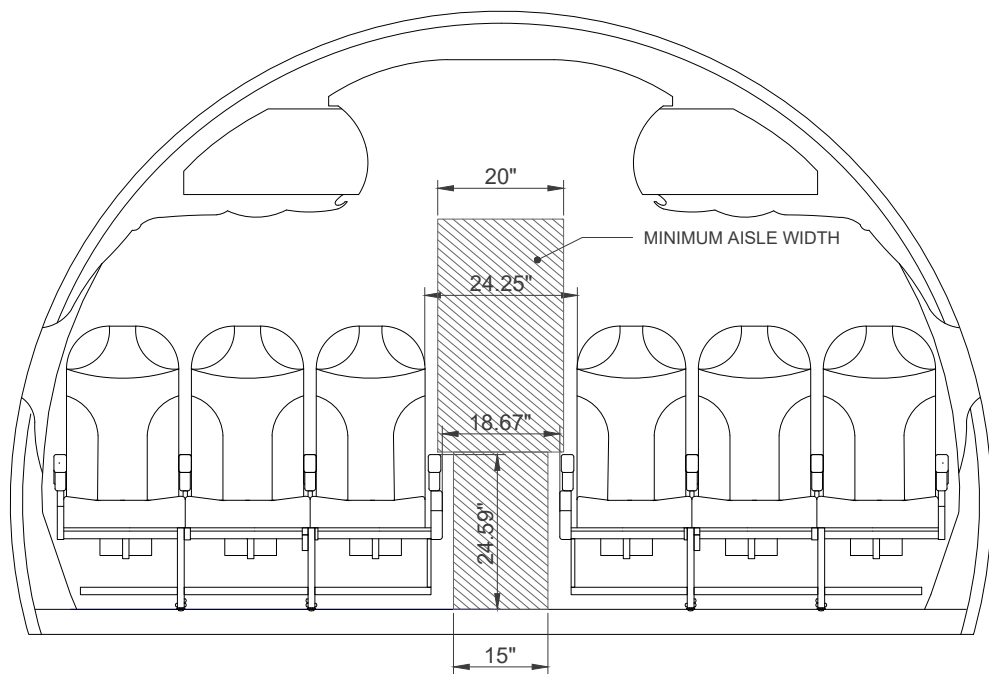

FIGURE 3 - D1. CONSTANT SECTION FRONT VIEW - MINIMUM AISLE WIDTH REQUIREMENTS

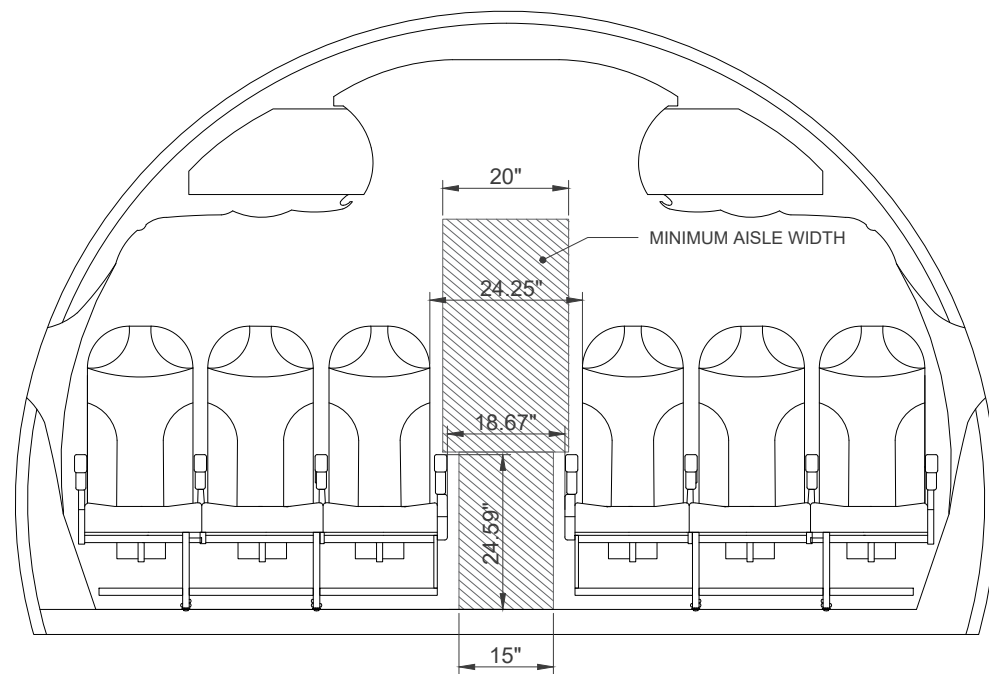

FIGURE 3 - D5. CABIN NARROW SECTION FRONT VIEW (C64) - MINIMUM AISLE WIDTH REQUIREMENTS

(REFER TO SHEET 1 FOR FURTHER INFORMATION)

**DRAWING INFORMATION:**  
This drawing is property of AIRE SL. It is issued on the condition that it is not copied, reproduced or disclosed to a third party either whole or in part without the consent in writing of AIRE SL



**TITLE:**  
LAYOUT OF PASSENGER ACCOMMODATIONS  
IN AIRBUS A320 MSN 3947

**PREPARED BY:**  
DESIGN OFFICE

**REFERENCE:**  
DWG-A320C110-3947-LOPA

**SIGNATURE**  
ON SHEET 1

**AIRCRAFT TYPE:**  
AIRBUS A320-232

**DIM:** in  
**SCALE:** N/A  
**SHEET:** 3/3  
**ISSUE:** 1